

LB2300

line boring machine for main and camshaft bearings

This kind of line boring machine is repairing machine tools with high efficiency and high precision, They can be used for boring master bushing and bushing of engine & generator's cylinder bodier in automobiles, tractors and ships etc. If necessary, the flywheel hub bore and bushing seat hole can be also finely bored, to be supplied with following accessories : accessories for centering, sectifying tool, measuring inner diameter, boring rod bracket, tool holder to increase diameter, boring tool micro-adjuster and for distance tool sectifying device can be provided with the main machine.

Gearbox moves 450mm and the main spindle traverses 550mm. Provide a high efficiency work and make the job congruously. The main spindle is inverter motor (stepless speed) 4 grades feed speed, widely used for work with different kinds of materials. The maximum working length of cylinder block up to 2300mm.

- 1 Handwheel for vertical adjustment of boring bar supporting pillars
- 2 Knob for cross adjustment of the boring bar
- 3 Hinged-type bearing housing
- 4 Boring bar central supports
- 5 Boring bar
- 6 Universal joint
- 7 Handwheel for turning the boring bar manually
- 8 Control panel
- 9 Handwheel for manual fast feed of the boring bar
- 10 Motor for spindle box move
- 11 Drive head supporting column lock lever

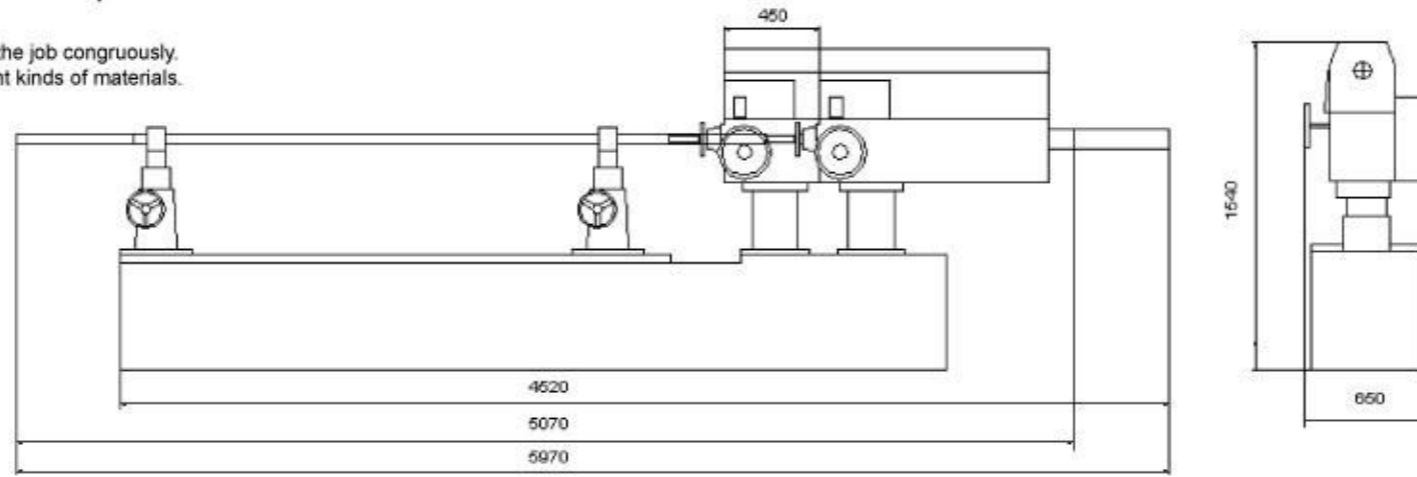

LB2300

line boring machine for main and camshaft bearings

Technical Specifications

Model	LB2300
Max. boring length of cylinder	2300mm
Range of boring diameter	Φ22~Φ250mm
Max. elongation of spindle	550mm
Max. movement of spindle box	450mm
Spindle speed	30-467rpm stepless
Boring spindle feed	0.044mm,0.078 mm,0.121 mm,0.176 mm
Main motor power	1.5kw
Motor power of spindle box	0.37 kw
Distance between center of spindle to surface of T slot	570mm~870mm
Overall dimension	4520×900×1540mm
Packing dimension:	4720×1000×1750mm
N.W./G.W.	2300/2500kgs

Accessories



centering sleeve



cylinder clamping device



boring sleeve & extending shaft(290mm)

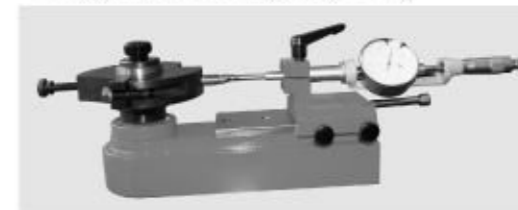

tool measuring device



measuring device & boring cutter

boring bar



Standard boring bar of LB2300 :

- boring bar Φ32, Φ45, Φ60
- Optional boring bar of LB2300 :
- boring bar Φ22
- tool measuring device(without gauge)

SJMC Machine Tools Co.,Ltd

Add:16/F,Jincheng House,No.511 Tianmu West Road,Shanghai China
Tel:0086-21-53550166 0086-21-63805442 Fax:0086-21-63805455
http://www.sj-mc.com http://www.sjmc.cm.cn E-mail:info@sj-mc.com