

T8115VF/T8120VF/T8125VF

line boring machine for main and camshaft bearings

This kind of line boring machine is repairing machine tools with high efficiency and high precision, They can be used for boring master bushing and bushing of engine & generator's cylinder bodier in automobiles, tractors and ships etc. If necessary, the flywheel hub bore and bushing seat hole can be also finely bored, to be supplied with following accessories : accessories for centering, sectifying tool, measuring inner diameter, boring rod bracket, tool holder to increase diameter, boring tool micro-adjuster and for distance tool sectifying device can be provided with the main machine.

- 1 Handwheel for vertical adjustment of boring bar supporting pillars
- 2 Knob for cross adjustment of the boring bar
- 3 Hinged-type bearing housing
- 4 Boring bar central supports
- 5 Boring bar
- 6 Universal joint
- 7 Handwheel for tuning the boring bar manually
- 8 Start and stop buttons
- 9 Change-over/reversing switch
- 10 Control handle for front-back movement of spindle
- 11 Control handle for presetting the automatic feed speed rate
- 12 Handwheel for manual fast feed of the boring bar
- 13 Drive head supporting column lock lever

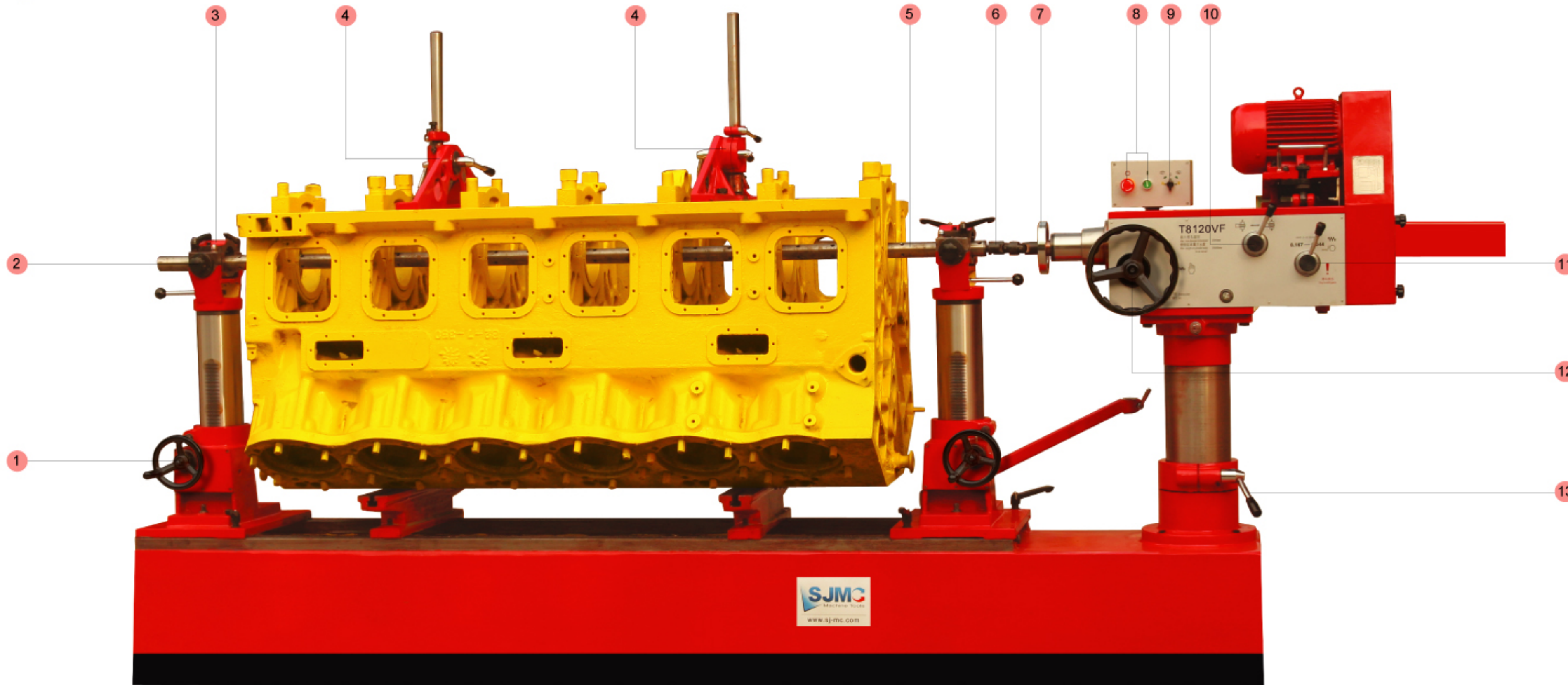
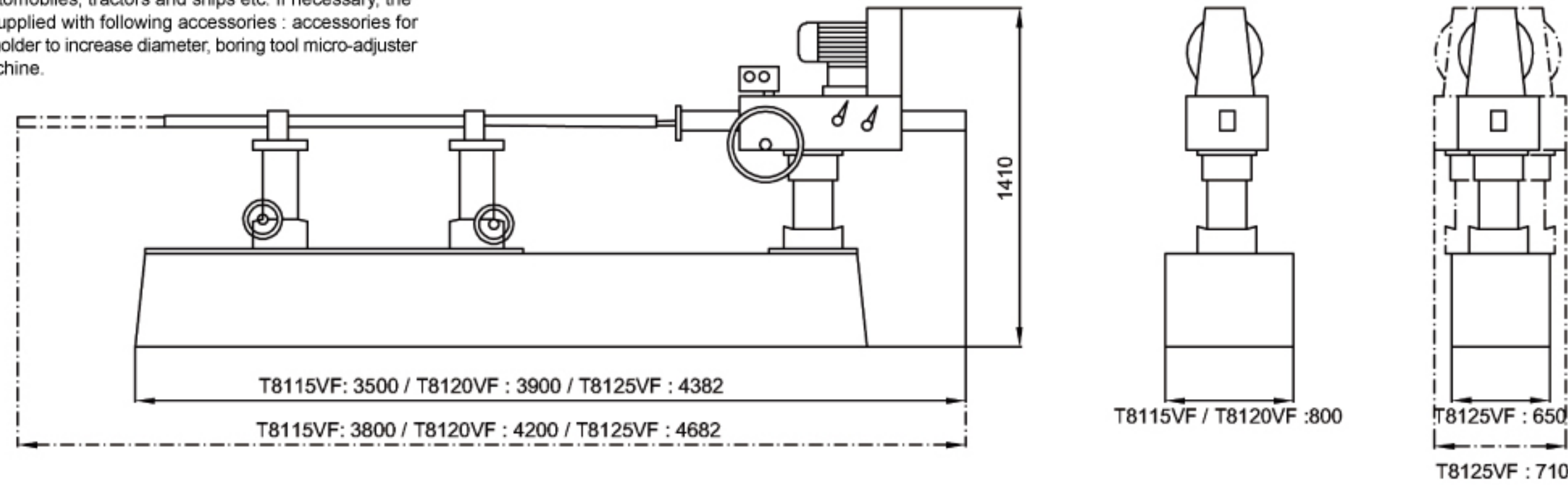

Technical Specifications

Model	T8115VF	T8120VF	T8125VF
Range of hole diameter to be bored	Φ36-Φ150mm	Φ36-Φ200mm	Φ28-Φ225mm
Max. length of cylinder body to be bored	1600mm	2000mm	2250mm
Main shaft max elongation	300mm	300mm	300mm
Main shaft rotating speed(stepless)	30-500rpm	30-500rpm	I: 30-150rpm; II: 93-467rpm
Boring shaft feed	0.044, 0.167mm/r	0.044, 0.167mm/r	0.43; 0.085; 0.125mm/r
Motor power	0.75/1.1Kw	0.75/1.1 Kw	1.5 Kw
Overall dimension (LxWxH)	3500x800x1500 mm	3900x800x1500mm	4382x650x1420mm
Packing dimensions (LxWxH)	3650x1000x1600 mm	4040x1020x1600mm	4040x1020x1700mm
N.W./G.W.	1900/2200 kg	2200/2500kg	2200/2500kg

Accessories

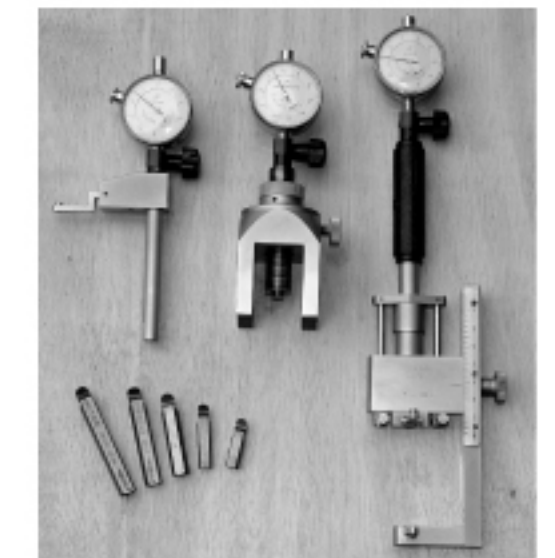

boring bar

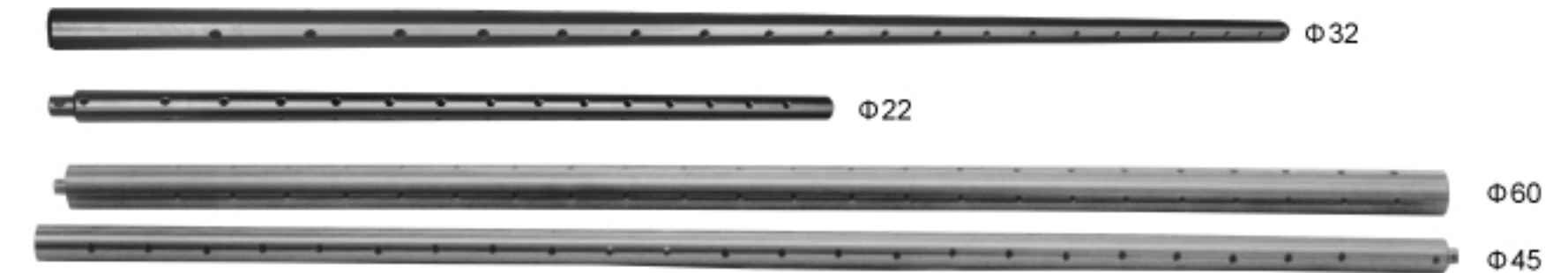

Standard boring bar of T8120VF :
boring bar Φ32, Φ45, Φ60
Optional boring bar of T8210VF :
boring bar Φ22

Standard boring bar of T8115VF :
boring bar Φ32, Φ45
Optional boring bar of T8115VF :
boring bar Φ22, Φ60

All boring bar of T8125 :

boring bar Φ22, Φ26 , Φ30 , Φ32, Φ37, Φ40, Φ45, Φ50, Φ60