

SG150/SG150A

hydraulic grinding-milling machine for cylinder heads & blocks

SG150/SG150A is the range of hydraulic grinding and milling machine for reconditioning of mating surfaces on small and medium sized cylinder heads and blocks. This model improved operating precision and more practical safer operation. SG150/SG150A use a two speed motor. High speed is for segmental wheel grinding casting blocks; low speed is for single-point tool for cutting aluminum. SG150A spindle feed control both by motor driving and handwheel. SG150/SG150A is also applicable for industrial grinding.

- Grinding head with rapid and normal speed move. A handwheel control the spindle move 0-60mm range. When the grinding head close to the workpiece, you can use the handwheel for a pinpoint move. Clamping device make the spindle sturdy.
- Work table move is driving by hydraulic system. The coolant tank separated from the machine ,for easy transfer to the emptying cleaning and filling site.
- Worktable runs on automatically lubricated double V-shaped ways. Provide good vibration absorption strong wear resistance and high precision.
- Automatic lubrication systems and manual lubrication oil pump ensure the machine in a good condition all the time.
- Controller is independently from the machine, conveniently positioned for checks and handling.

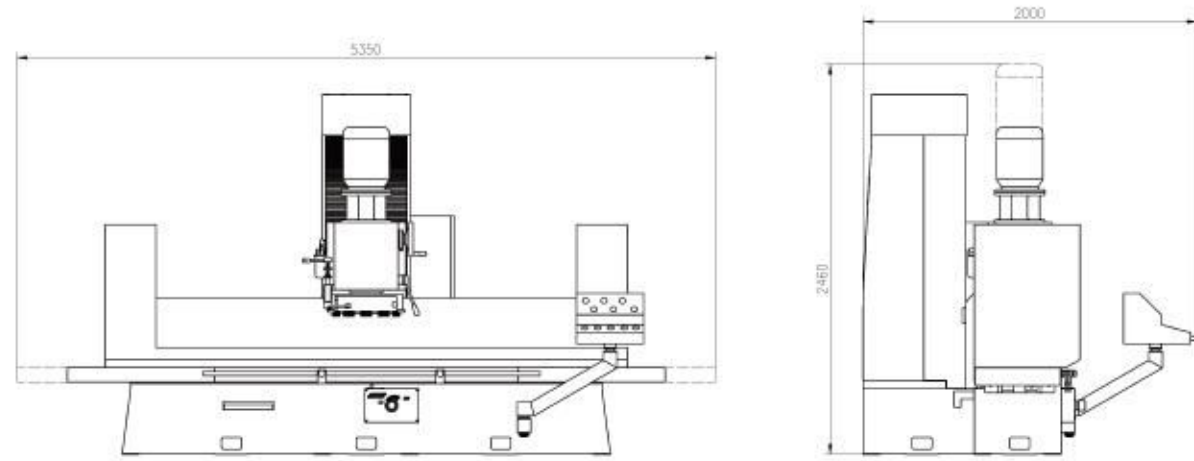

Technical Specifications

Model	Unit	SG150	SG150A(Automatic Feed)
Max. automatic table traverse(Hydraulic)	mm	1800	1800
Vertical wheel head traverse	mm	800	800
Vertical spindle traverse (with digital read out)	mm	60 (30)	60 (30)
Max. grinding width	mm	400	400
Max. grinding length	mm	1600	1600
Max. milling width	mm	370	370
Max. milling length	mm	1600	1600
Working table size	mm	1500x400	1500x400
Distance from spindle nose to work table	mm	0-800	0-800
Distance from column to worktable center	mm	380	380
Grinding wheel size	mm	400	400
Grinding wheel speed	r/min	700/1400	700/1400
Grinding head move speed	mm/min	900	900
Automatic cross feed for grinding head	mm/ cycle	-----	0.01 0.02 0.03 0.04 0.05
Table traverse feed speed (stepless)	mm/min	0-5000	0-5000
Grinding wheel motor	kw	3.3/2.2kw	3.3/2.2kw
Grinding wheel rapid move motor	kw	0.55	0.75(frequency inverter-motor)
Hydraulic motor	kw	0.75	0.75
Coolant pump	kw	0.09	0.09
Overall dimensions (LxWxH)	mm	3550x2000x2140	3550x2000x2140
Packing dimensions (LxWxH)	mm	3800x2210x2240	3800x2210x2240
N.W./G.W.	kg	2800/3400	2800/3400



- Lubrication system for spindle
- Wheel dresser
- Surface straightness check device
- Holding arm with segmental wheel
- Centralized lubrication system
- Double speed motor
- Handwheel for spindle move
- Clutch for spindle
- Grinding head
- Electric box
- Moveable main control panel
- Worktable hydraulic controller
- Limit block
- Tooling plate

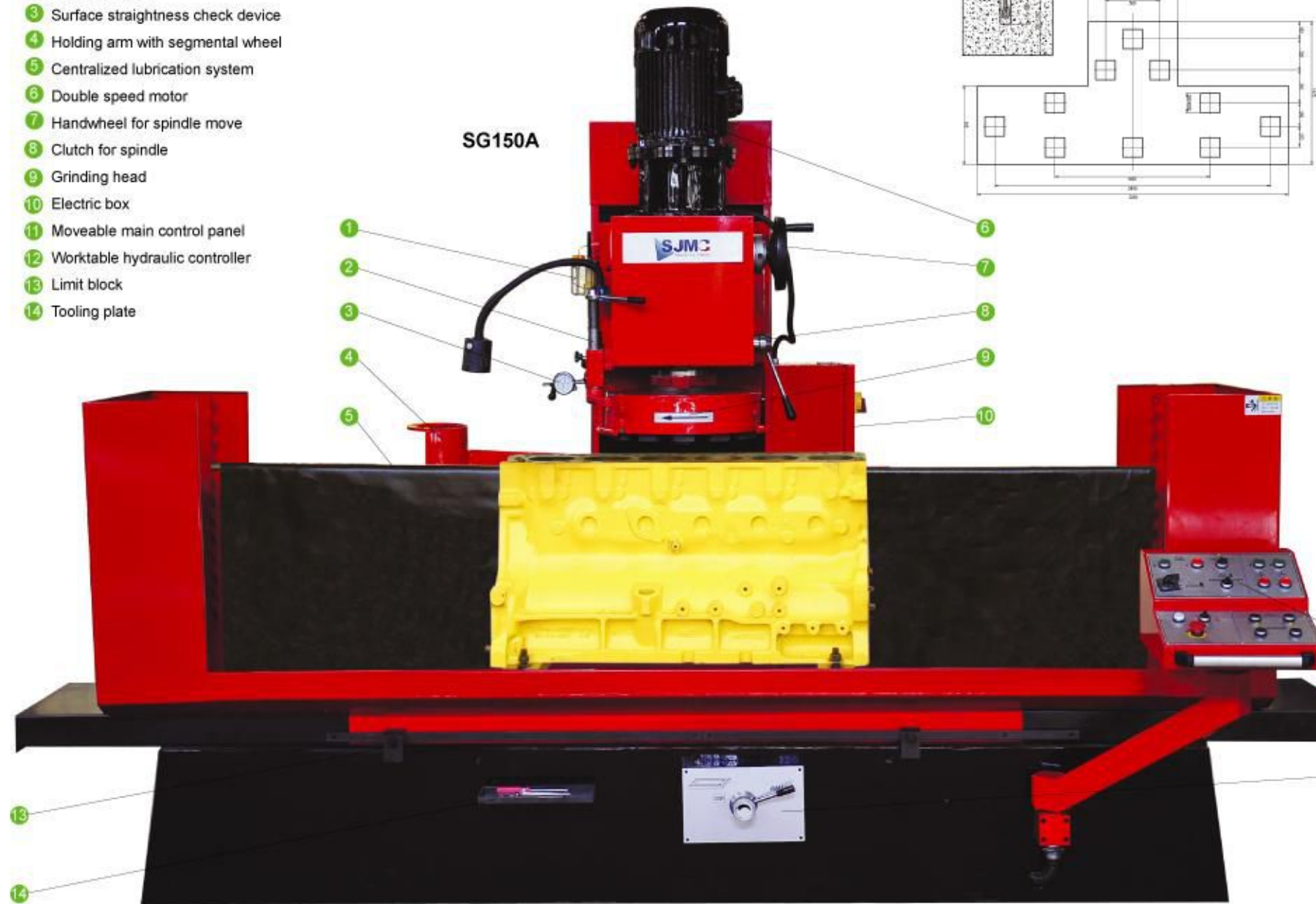

Accessories

hydraulic grinding-milling machine for cylinder heads & blocks SG150/SG150A



Table of Standard and Optional Accessories

Model	Standard Accessories	Optional Accessories
SG150	1,2,3,4,5,6,7	8,9,10,11,12
SG150A	1,2,3,4,5,6,7	8,9,10,11,12

Hydraulic grinding-milling machine for cylinder heads & blocks